

# "PARTLOW SUBDIVISION"

A REPLAT OF LOTS 19, 20, 21, 22, & 23, BLOCK 46, (TOWN) NOW CITY OF IRRIGON, IN THE SW 1/4 OF SECTION 19, T 5 N, R 27 E, W.M., MORROW COUNTY, OREGON

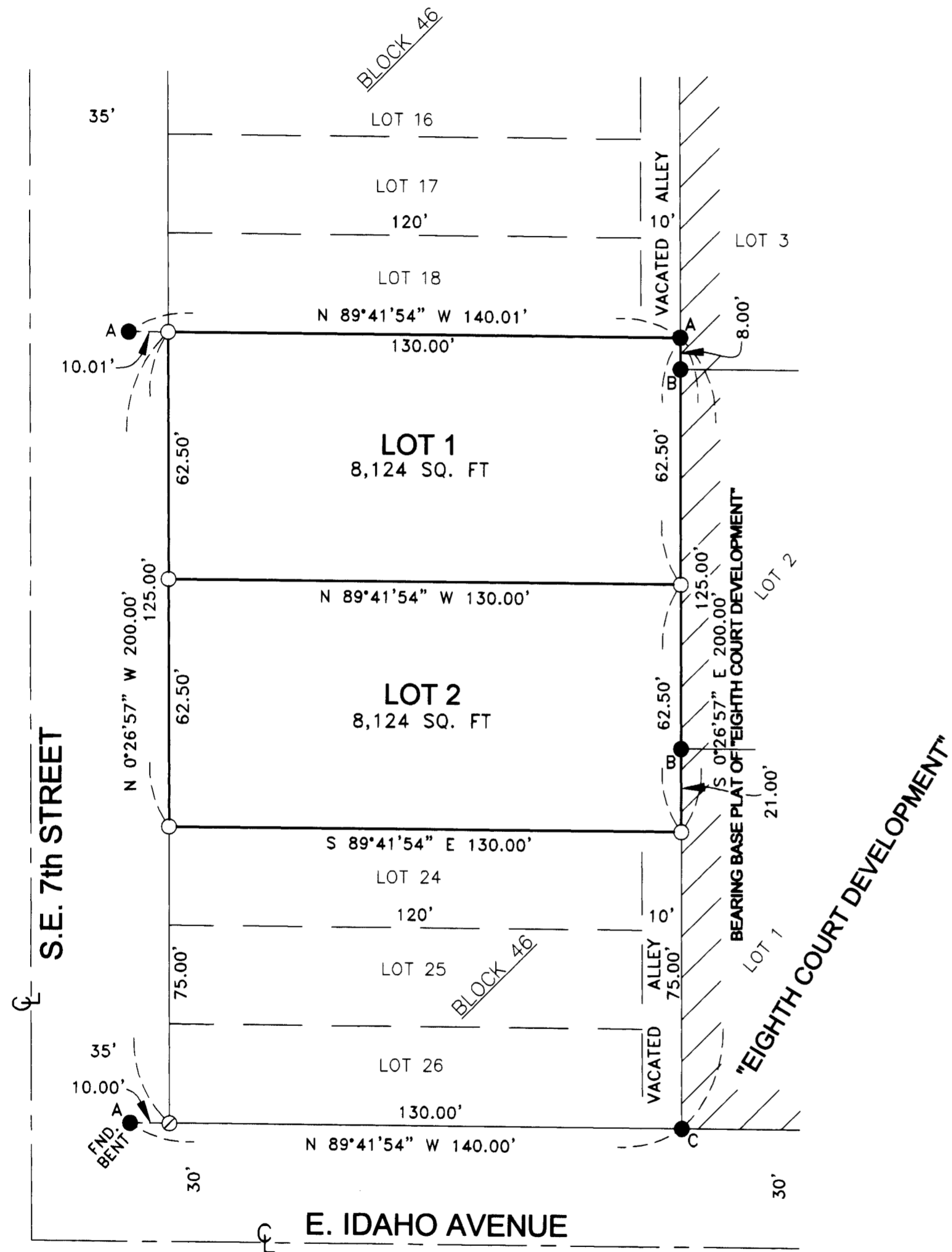

### SURVEYOR'S NARRATIVE & CERTIFICATE:

I, G. DENNIS EDWARDS, AM A REGISTERED SURVEYOR OF THE STATE OF OREGON AND HAVE MARKED WITH LEGAL MONUMENTS THE LAND SHOWN ON THIS PLAT.  
 I SURVEYED LOTS 19 THROUGH 26, BLOCK 46 FOR PARTLOW IN 1996 AND THE WEST TWO CORNERS WERE 10 FOOT OFFSETS. THE EAST LINE OF THIS TRACT IS THE WEST LINE OF "EIGHTH COURT DEVELOPMENT" WHICH IS THE BEARING BASE FOR THIS PLAT.  
 I CONDUCTED THIS SURVEY WITH A TOPCON HIPER+ G.P.S.  
**DESCRIPTION:** LOTS 19, 20, 21, 22, AND 23, BLOCK 46, "IRRIGON", IN THE CITY OF IRRIGON, MORROW COUNTY, OREGON, ALSO THAT PORTION OF THE VACATED ALLEY THAT INURED THERETO,

REGISTERED PROFESSIONAL LAND SURVEYOR  
 OREGON  
 JULY 16, 1971  
 G. DENNIS EDWARDS  
 9 5 1  
 RENEWS 12/31/2009

*G. Dennis Edwards*

### OWNER'S DECLARATION & DEDICATION:

WE, THE OWNERS OF THE ABOVE DESCRIBED LAND, HEREBY DECLARE THAT WE HAVE CAUSED THIS PLAT TO BE PREPARED.

*James D. Ray*  
 JAMES RAY, CITY OF IRRIGON MAYOR

*Gerald Breazeale*  
 GERALD BREAZEALE, IRRIGON CITY MANAGER

STATE OF OREGON }  
 COUNTY OF MORROW }  
 BEFORE ME THIS 20 DAY OF Aug., 2009  
 APPEARED JAMES RAY, CITY OF IRRIGON MAYOR AND GERALD BREAZEALE, IRRIGON CITY MANAGER AND ACKNOWLEDGED THE FOREGOING DEDICATION.

*Emerald Cantis*  
 NOTARY PUBLIC FOR OREGON  
 PRINTED NAME Emerald Cantis  
 COMMISSION NO. 240 410492  
 MY COMMISSION EXPIRES Oct. 3, 2010

### LEGEND:

- FOUND MONUMENTS
  - A 5/8" I. REBAR, MY 1996 SURVEY FOR PARTLOW
  - B 5/8" I. REBAR, MY 2007 PLAT OF "EIGHTH COURT DEVELOPMENT"
  - C 5/8" I. REBAR, MY 1996 SURVEY FOR GROW, ET AL.
- SET 5/8"X30" IRON REBAR WITH PLASTIC CAP #951
- ⊙ COMPUTED LOCATION

### APPROVALS:

MORROW COUNTY SURVEYOR  
 APPROVED THIS 24 DAY OF Aug., 2009  
*John H. Cooper*  
 MORROW COUNTY SURVEYOR

WEST EXTENSION IRRIGATION  
 APPROVED THIS 20<sup>th</sup> DAY OF Aug., 2009  
*Beverly J. Bridgewater*  
 MANAGER

CITY OF IRRIGON  
 APPROVED THIS 2nd DAY OF June, 2009  
*Gerald Breazeale*  
 IRRIGON CITY MANAGER

MORROW COUNTY COURT  
 APPROVED THIS 26<sup>th</sup> DAY OF August, 2009  
*James K. Tallman* COUNTY JUDGE  
*Stamm Pea* COMMISSIONER  
 ABSENT  
 COMMISSIONER

MORROW COUNTY ASSESSOR & TAX COLLECTOR  
 PROPERTY TAXES ARE PAID IN FULL.  
 APPROVED THIS 24 DAY OF August, 2009  
*John Paul*  
 MORROW COUNTY ASSESSOR & TAX COLLECTOR

STATE OF OREGON }  
 COUNTY OF MORROW } SS  
 I HEREBY CERTIFY THAT THE WITHIN INSTRUMENT WAS RECEIVED AND FILED FOR RECORD ON THE 26<sup>th</sup> DAY OF August, 2009 A.D. AT 9:49 O'CLOCK A. M. AND RECORDED AS FILE NO. 2009-24581  
 MORROW COUNTY CLERK \_\_\_\_\_  
 DEPUTY \_\_\_\_\_

RECEIVED BY  
 Morrow County Surveyor  
 Date AUG 28 2009  
 Rec'd By SKB  
 No. 1548-C

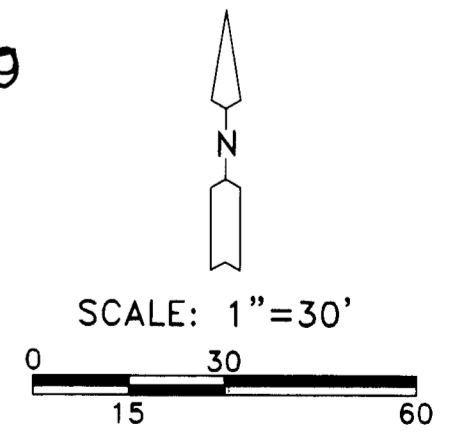

THIS IS AN EXACT COPY: *G. Dennis Edwards*  
 G. DENNIS EDWARDS

JOB# S0903019  
 EDWARDS SURVEYING P.O. BOX 763  
 541-567-3336 HERMISTON, OREGON 97838  
 DRAWN BY JMC