

**NARRATIVE:**

THE PURPOSE OF THIS SURVEY IS TO STAKE THE CORNERS OF LOT 6, BLK 3 "HILLVIEW ESTATES" SO SEE WHERE A SANITARY SEWER LIES ON SAID LOT.

I RETRACED KRUMBEIN'S ORIGINAL 1976 PLAT TO ESTABLISH THE MISSING CORNERS OF LOT 6. THE FRONT TWO MONUMENTS WERE ABOUT 5" BELOW THE SURFACE. THE FENCE LINES IN THE BACK PORTION OF THE LOT ARE WITHIN A FOOT OF THE PROPERTY LINE.

I FOUND THAT THE CENTER OF THE SANITARY SEWER MAN HOLE LIES 3.7 FEET OUTSIDE OF THE UTILITY EASEMENT IN THE BACK OF THE LOT. THE SEWER LINES ARE ESTIMATED. I COULD FIND NO MAN HOLE WEST OF THIS LOT. THE MAN HOLE EAST IS IN THE CENTER OF FALER ROAD AND THE SEWER LINE RUNS APPROXIMATELY AS SHOWN.

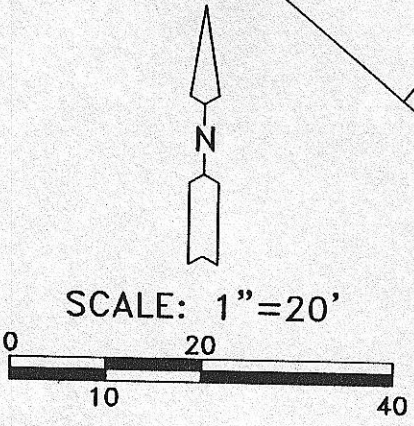

RECEIVED BY  
 Morrow County Surveyor  
 Date Oct 19, 2006  
 Rec'd By SKB  
 No. 1482-B

REGISTERED  
 PROFESSIONAL  
 LAND SURVEYOR

*G. Dennis Edwards*

OREGON  
 JULY 16, 1971  
 G. DENNIS EDWARDS  
 9 5 1  
 RENEWS 12/31/2007

- LEGEND:**
- FND. 1/2" IRON REBAR, 1976 ORIG. SUR.
  - SET 5/8" IRON REBAR-PLASTIC CAP 951
  - (000) OF RECORD, 1976 PLAT OF "HILLVIEW ESTATES"

MAP FOR BILL ESTES  
 LOT 6, IN BLOCK 3, "HILLVIEW EST,"  
 IN NW 1/4 SEC. 17, T 4 N, R 25 E,  
 W.M., MORROW COUNTY, OREGON  
 09/26/2006 JOB#S0609164  
 EDWARDS SURVEYING P.O. BOX 763  
 541-567-3336 HERMISTON, OR 97838  
 DRAWN BY JMC